

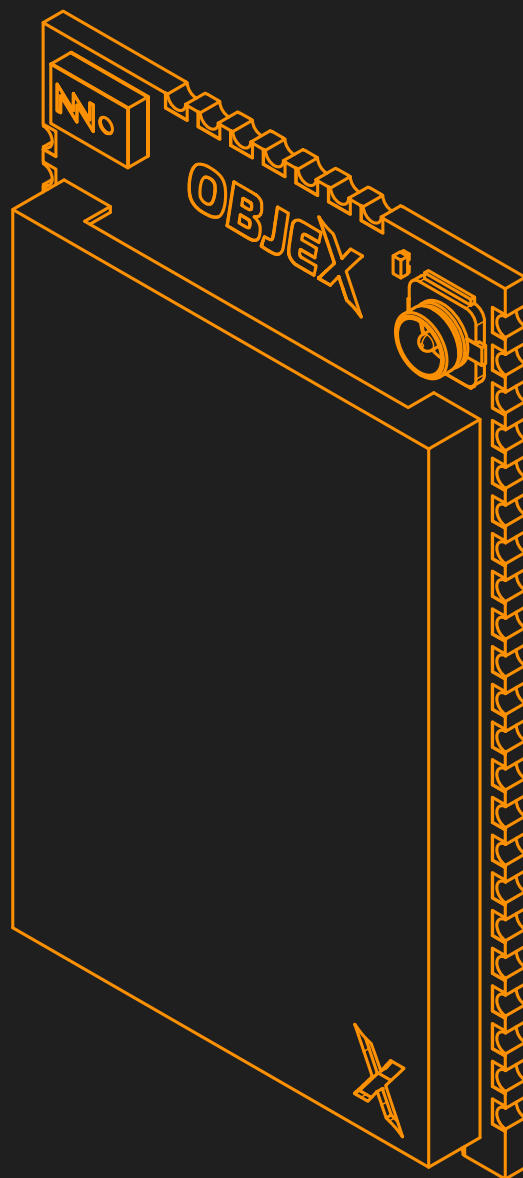

# ELPM-S3LW

Extreme Low Power Module based on ESP32-S3FN8 and SX1262

v1.2 LW-B



## Overview

The ELPM-S3LW is extreme-low power module based on ESP32-S3FN8 and SX1262. Designed for development of IoT devices or generic applications, especially battery-powered devices and energy harvesting applications. The module has a power unit designed to adapt to each specific use. Together with the deep stop mode, it minimizes power consumption. This makes the ELPM-S3LW an excellent choice for industrial applications and devices that require high energy efficiency.

## Features

### Microcontroller

- > Based on ESP32-S3FN8 (32-bit 240MHz)
- > Memory Size: 8MB Flash
- > GPIO: 33 available (7 reserved for LoRa - SPI)
- > WiFi - IEEE 802.11 b/g/n-compliant
- > Bluetooth LE: Bluetooth 5, Bluetooth mesh
- > Wi-Fi and Bluetooth share the same antenna
- > Cryptographic hardware acceleration
- > External PSRAM can be installed
- > Interfaces: I<sup>2</sup>C, I<sup>2</sup>S, SPI, UART, USB
- RGB status led (WS2812B)
  - > PIN: GPIO48
- Integrated I2C pullup resistors
  - > SDA: GPIO8
  - > SCL: GPIO9
- > Ceramic antenna (WiFi/BLE)
- > 50 Ohm pin (WiFi/BLE)

### LoRa

- > Based on SX1262
- > Frequency bands: 862MHz to 928MHz
- > Signal power: 22dBm
- > Transmission distance: 10km
- > Communication interface: SPI
- > Air data rate: 0.3kbps to 62.5kbps
- > Dissipation Power: 1W
- > 50 Ohm U.FL/pad antenna
- > Dedicated LD02 3.3V@300mA
- > Dedicated 3.3V pad
- > Full compatibility with LoRa and LoRaWAN

### Deep Stop

- > Dedicated LD01 3V3@300mA for ESP32
- > Rising/falling edge detector (1-30nA)
- > Wake and Gate input (1-30nA)
- > RTC RV-3028-C7 (45-100nA)
- > Dedicated RTC power supply pad
- > Battery level circuit (zero leakage current)

### Deep Stop Mode (Extreme low power)

An effective alternative to the deep sleep mode of the ESP32-S3FN8. Deep Stop mode consists of a power latch and RTC combined with a smart power management system that controls the ESP32-S3FN8, SX1262, and all loads connected to the 3V3 path. By controlling the power supply to all connected loads, it is possible to minimize power consumption, thus increasing the life of the battery. In addition, an external mosfet can be driven (gate pin) to control multiple loads.

### Applications

- Battery-powered nodes
- Smart meters
- Assets Tracking
- Smart cities
- Street Lights
- Supply chain
- Building automation
- Energy harvesting
- Smart Agriculture
- Environmental Sensors

Block diagram

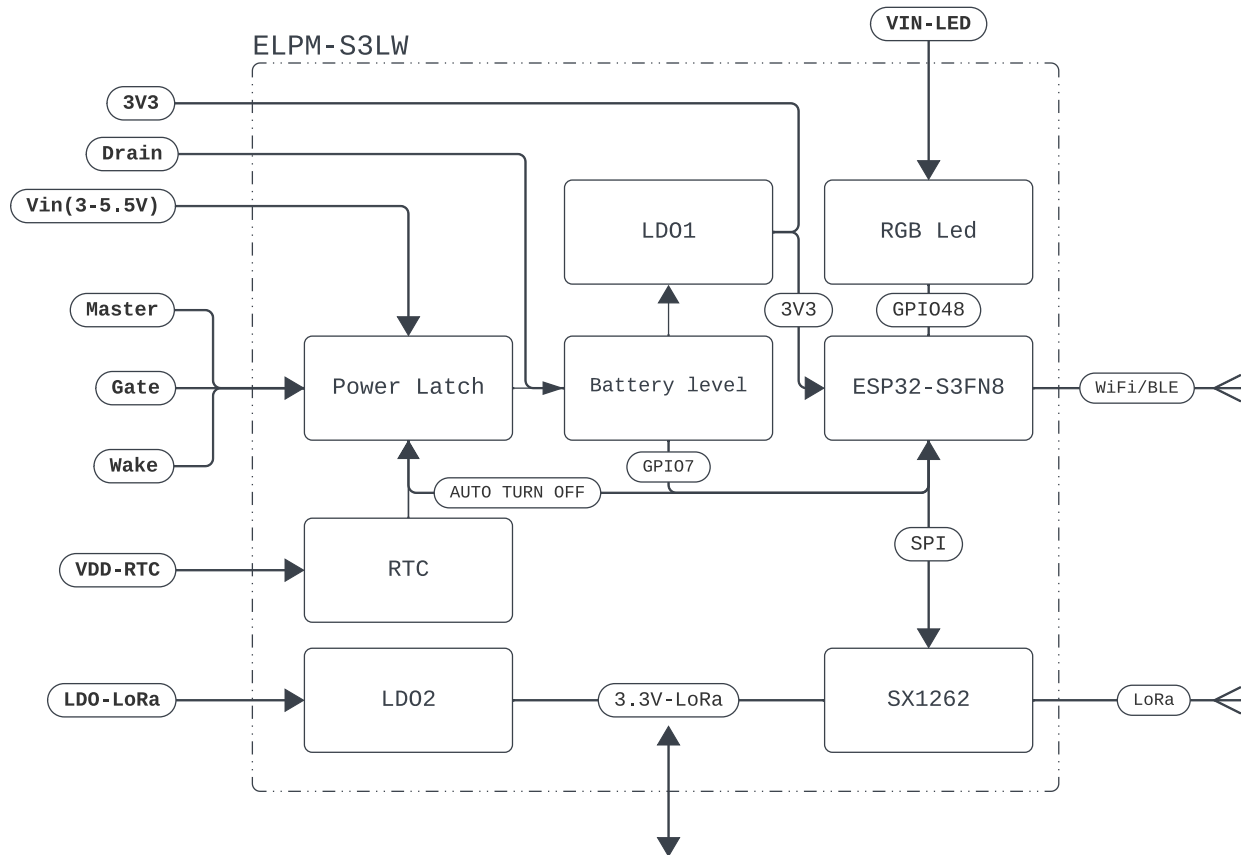

**3V3:** Main power path for the ESP32-S3FN8.

**Vin:** Power path handled by the power latch, ideal for a battery.

**Master:** Power latch input: If the status change(0 to 1 || 1 to 0) the P.L. is triggered.

**Gate:** Power latch input: If low, the power latch is activated instantly.

**Wake:** Power latch input: If low, the power latch is triggered with a short startup delay.

**Drain:** Power latch: path between the control block and the input of the primary LDO.

**AUTO TURN OFF:** Input signal to trigger shutdown by power latch.

**Vdd-RTC:** Power path reserved for RV-3028-C7.

**LD0-LoRa:** LDO input reserved for SX1262.

**3.3V-LoRa:** Power path reserved for SX1262.

**VIN-LED:** Power path reserved for the RGB LED.

# OBJEX

BEHIND EVERY REVOLUTION

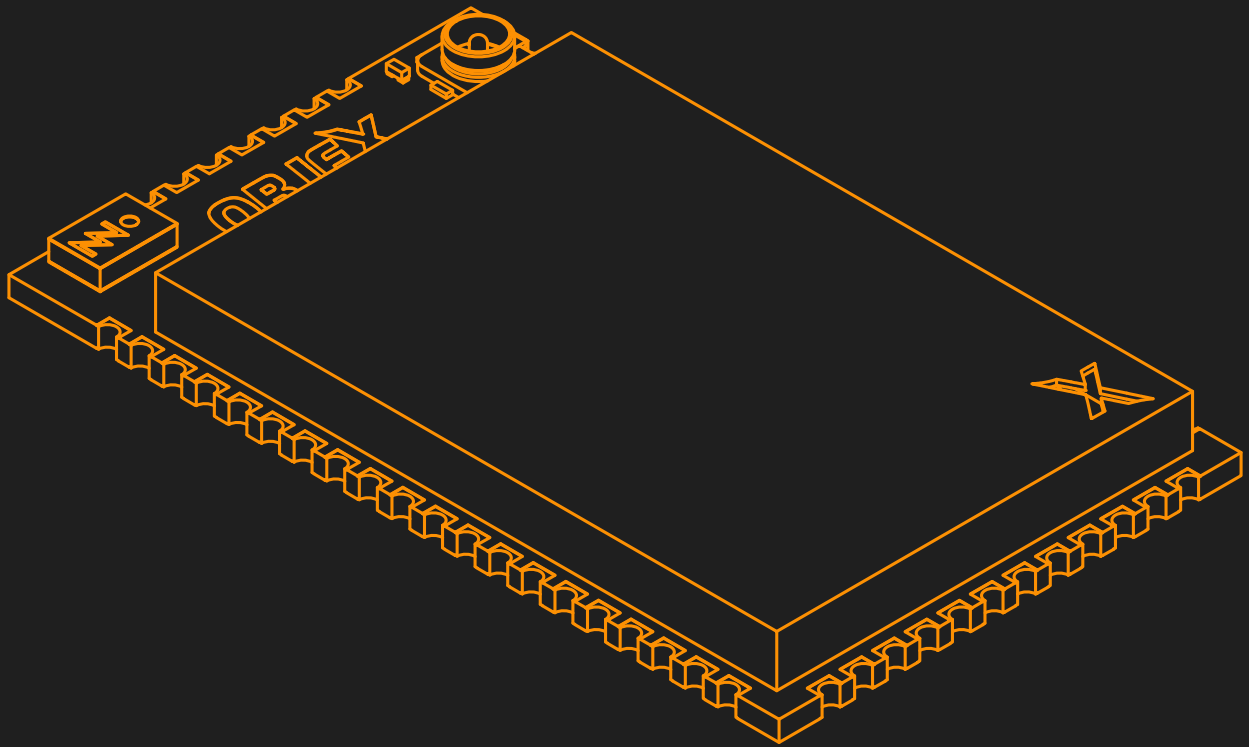

Full Datasheet  
OBJEXLABS.COM